

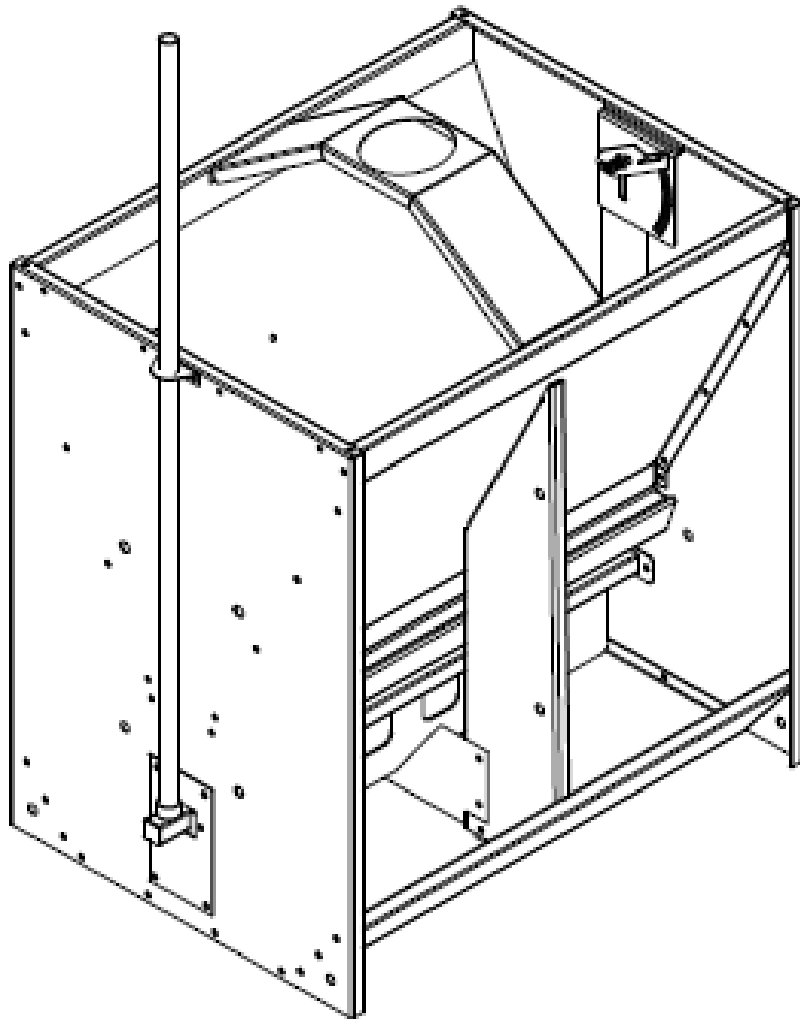

Wet/Dry Feeder Bolted 30" X 31" Adjustment Plate Assembly Instructions (Includes Spanish Version)

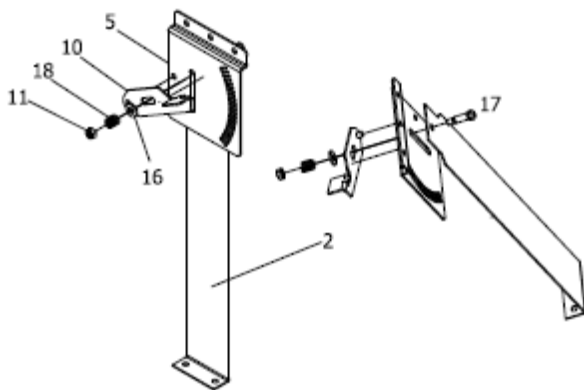

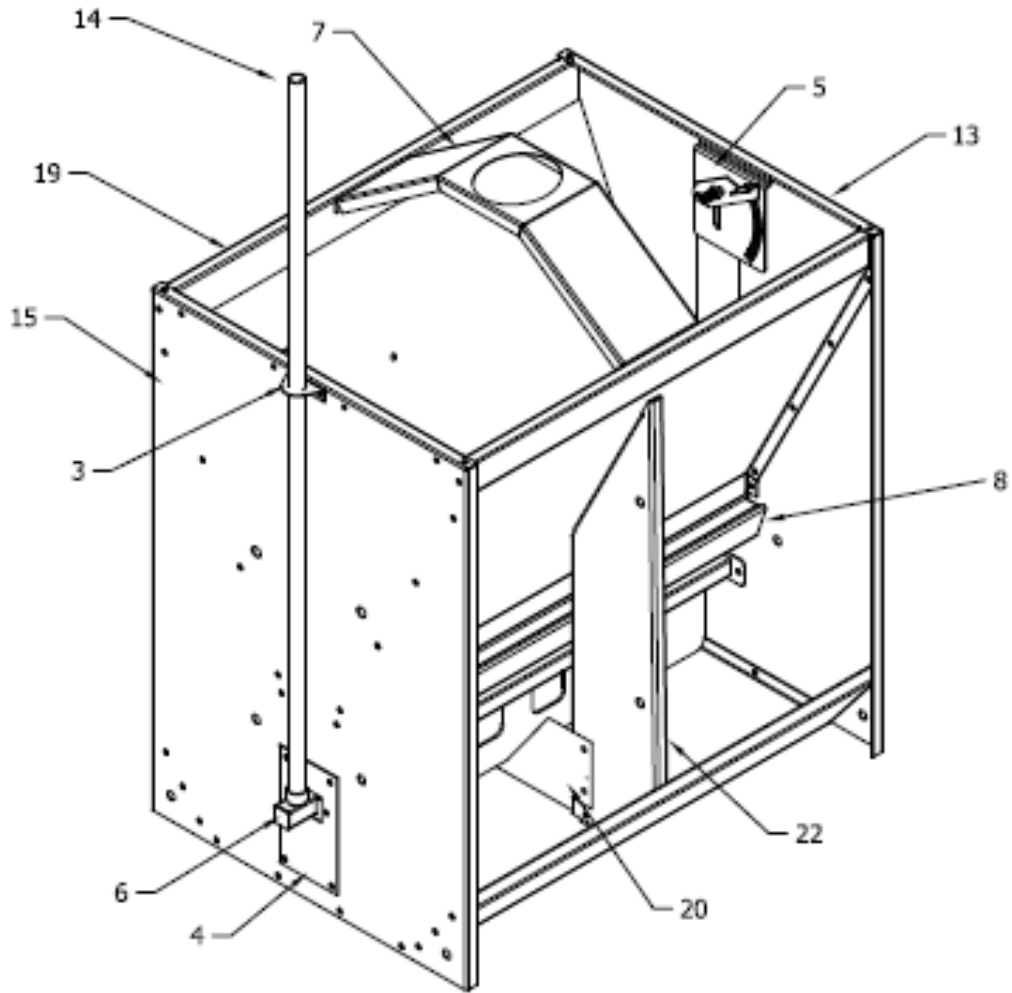

Apply grease to mated surfaces.
Tighten locknut till nylon is past threads on bolt.

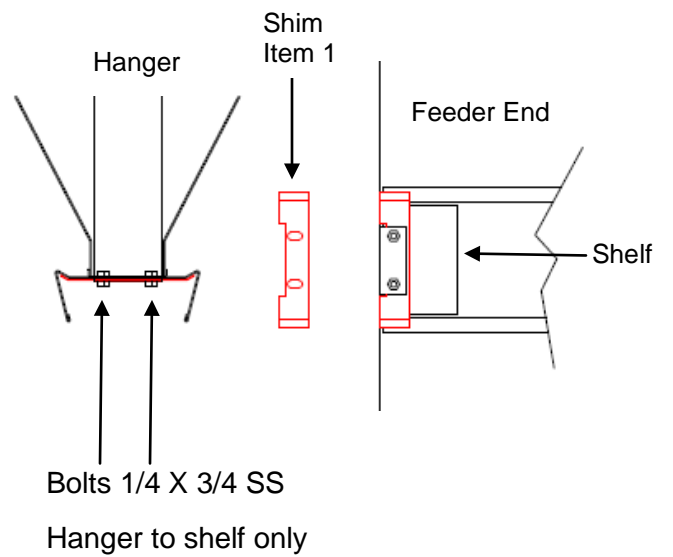

Item	Description
1	Wet/Dry Adjustment Shim
2	Wet/Dry Shelf Hanger
3	Wet/Dry Water Pipe Holder (Bent)
4	Wet/Dry End Cap (Punch)
5	Wet/Dry Adjustment Plate (Bent)
6	Wet/Dry Water Tube with Plug
7	Wet/Dry Cross Brace (Bent)
8	Wet/Dry Shelf (Spot Weld)
9	Bottom Welded
10	Wet/Dry Lever (Weld)
11	Locknut 1/4 SS
12	Bolt 1/4 X 1/2 SS
13	Wet/Dry End Closed End
14	48" SS Pipe Thread Both Ends
15	Wet/Dry End with Opening
16	Flat Washer 5/16 SS
17	Shoulder Bolt 5/16 X 3/4
18	Spring SAF05 .480 X .063 X .875 SS
19	Side Panel
20	Wean Blocker
21	Bolt 1/4 X 3/4 SS
22	Bolt in Divider
23	Feeder Label

Assembling

Assemble adjustment to ends tight.

Snug bolts through hanger, shim, and shelf.

Place lever in (0) position before tightening bolts in side.

Side should sit flush to shelf.

Recheck shim and hanger placement to ends and tighten shelf.

All bolts are 1/4" X 1/2" except on shelf to hanger (they are 1/4" X 3/4").

All bolts and locknuts are stainless steel.

This equipment must be installed in accordance with all State and Local Codes and applicable Regulations which should be followed in all cases. Authorities having jurisdiction should be consulted before installations are made.



**Hog Slat, Inc.
PO Box 300
Newton Grove, NC 28366**

**Phone: (910) 594-0219
Fax: (910) 594-1392**

www.hogslat.com

Copyright © 2016 by Hog Slat, Inc.

Part Number: HSMANUAL-115 REV IR



Comedero Húmedo/Seco Atornillado 30" X 31" Instrucciones de Montaje de la Placa de Ajuste

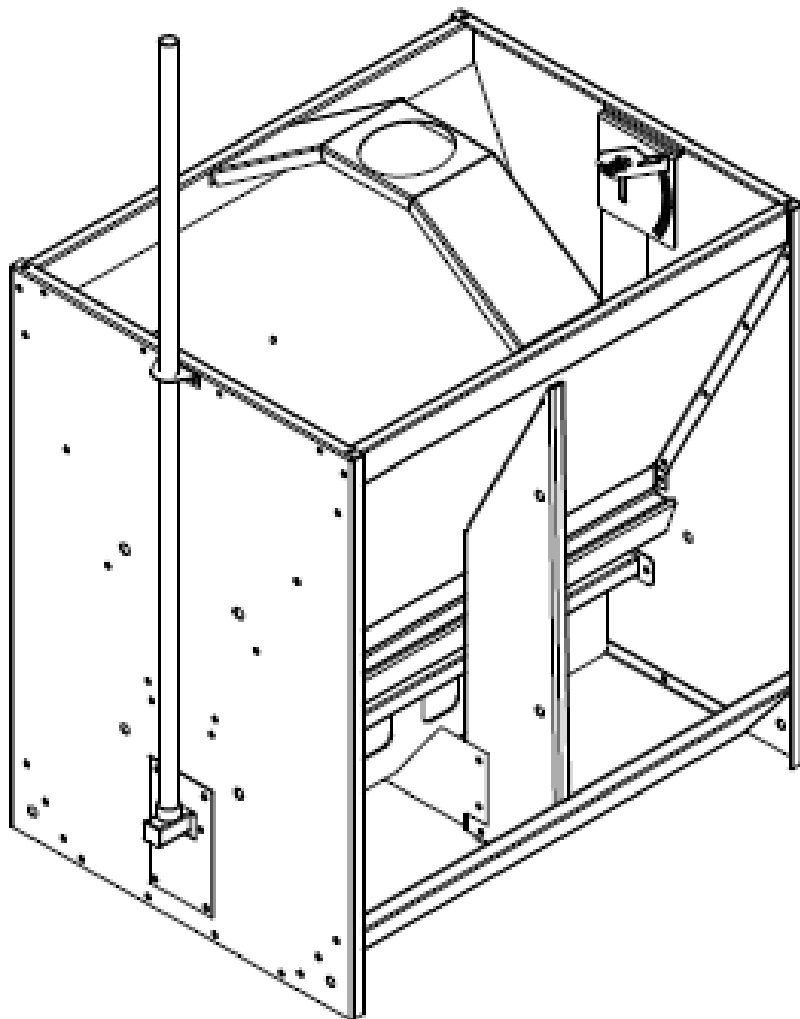

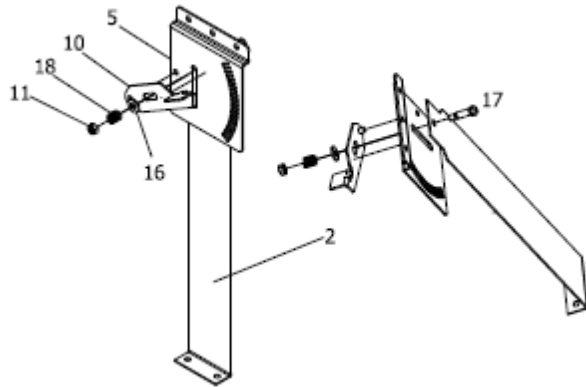
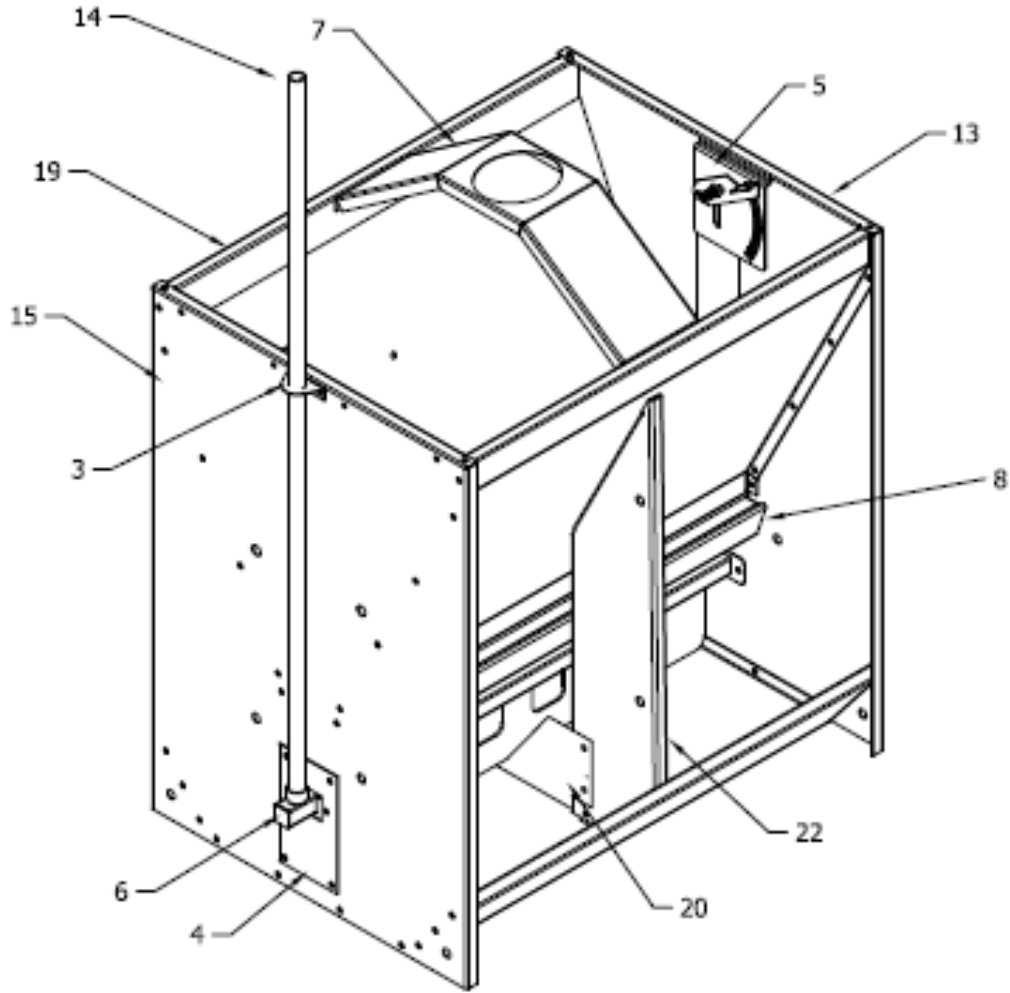

Aplique grasa a las superficies apareadas
 Apriete la tuerca de seguridad hasta que el nylon
 haya pasado las roscas del tornillo

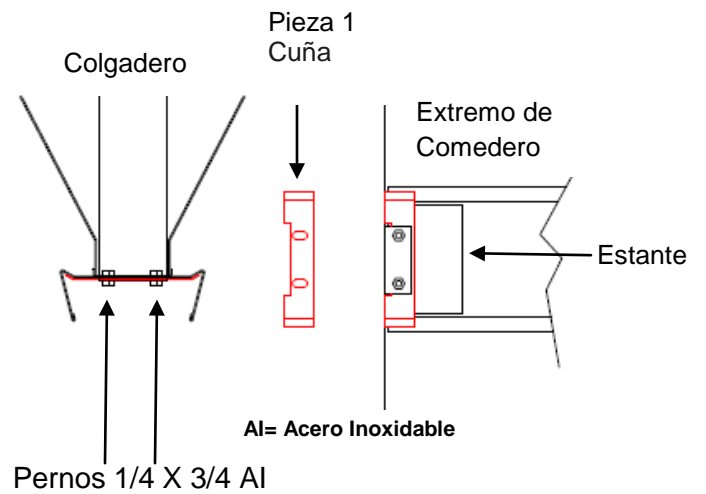

De colgadero a estante solamente

Al= Acero Inoxidable

Pieza	Descripción
1	Cuña de ajuste - húmedo / seco
2	Colgadero de Estante - húmedo / seco
3	Soporte de Tubería de Agua (doblado) - húmedo / seco
4	Tapón de extremo (perforado) - húmedo / seco
5	Plato de Ajuste (Doblado) - húmedo / seco
6	Tubo de Agua con Tapón- húmedo / seco
7	Soporte Cruzado (Doblado) - húmedo / seco
8	Estante - húmedo / seco (Puntos de Soldadura)
9	Fondo Soldado
10	Palanca niveladora - húmedo / seco (Soldada)
11	Tuerca de bloqueo 1/4 AI
12	Perno 1/4 X 1/2 AI
13	Extremo Cerrado Final - húmedo / seco
14	Tubo con Rosca en ambos extremos 48" AI
15	Extremo con Abertura - húmedo / seco
16	Arandela Plana 5/16 AI
17	Perno 5/16 X 3/4
18	Resorte SAF05 .480 X .063 X .875 AI
19	Panel Lateral
20	Bloqueador de Destete
21	Perno 1/4 X 3/4 AI
22	Perno en Divisor
23	Etiqueta de Comedero

Montaje

Montar ajuste a los extremos firmemente.

Ajustar los pernos a través del colgador, cuña y estante.

Posicionar nivelador en la posición (0) antes de apretar los pernos en extremo.

Lado debe estar a nivel con el estante.

Volver a revisar cuña y colocación del colgador a los extremos y apretar el estante.

Todos los pernos son de 1/4" X 1/2" excepto en el del estante al colgador (esos son de 1/4" X 3/4").

Todos los pernos y tuercas de bloqueo son de acero inoxidable.

Este equipo debe ser instalado de acuerdo con todos los códigos estatales y locales y reglamentos aplicables que deben seguirse en todos los casos. Las autoridades competentes deben ser consultadas antes de que se efectúen las instalaciones.



Hog Slat, Inc.
PO Box 300
Newton Grove, NC 28366

Phone: (910) 594-0219
Fax: (910) 594-1392

www.hogslat.com

Copyright © 2016 by Hog Slat, Inc.

Part Number: HSMANUAL-115 REV IR