

POTTERS ARE LEADING SUPPLIERS OF CAGE FREE POULTRY EQUIPMENT

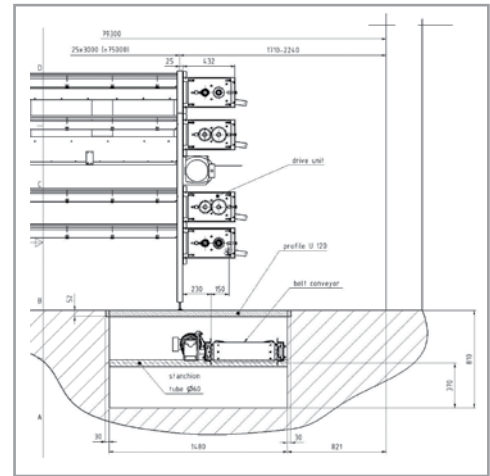

Multi-tier aviary

Cage free - free range



Heavy duty drive sets ensure long-term reliability

The Potters Poultry multi-tier aviary system is different. Why? It is designed by farmers to be used by farmers. It is designed with easy bird management as a priority. It is the most open system available making it better to see and manage the hens.

A fully integrated system packed with features:

- A simple support system with very little of the structure fixed to the floor - meaning easy cleaning.
- An endlessly adaptable system to suit any building.
- Lighting available on all levels to minimise floor eggs.
- Minimal distances between tiers to reduce flight requirements of hens, therefore reducing injury.
- Choice of belt numbers to suit layout design and building dimensions.
- Ideally suited to new, refurb or conversion projects.
- All necessary perching provided within the system.
- Supplied as part of a complete package to provide a turnkey project.
- Supplied by a UK company with 25 years experience with manure belts and nesting within Free Range and Barn.

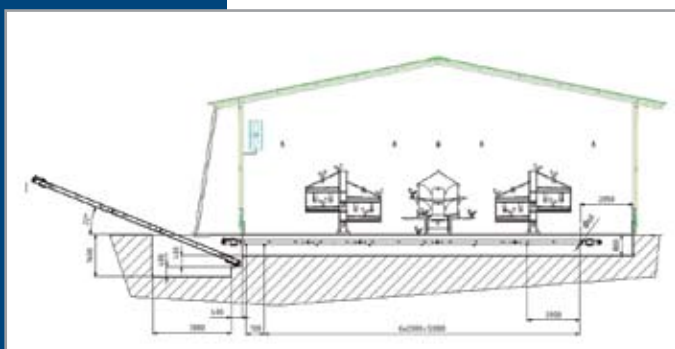

Flexible modular systems mean any poultry house can have aviary systems installed

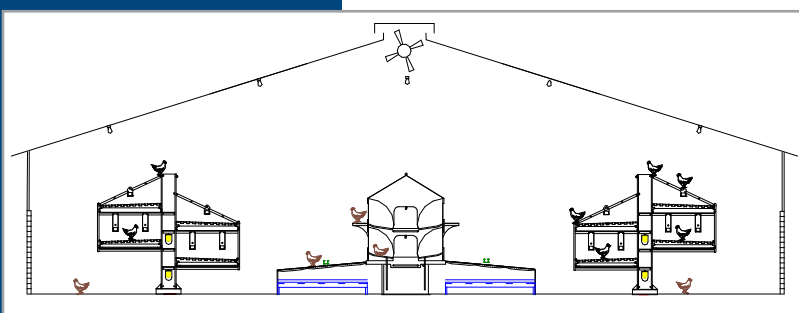
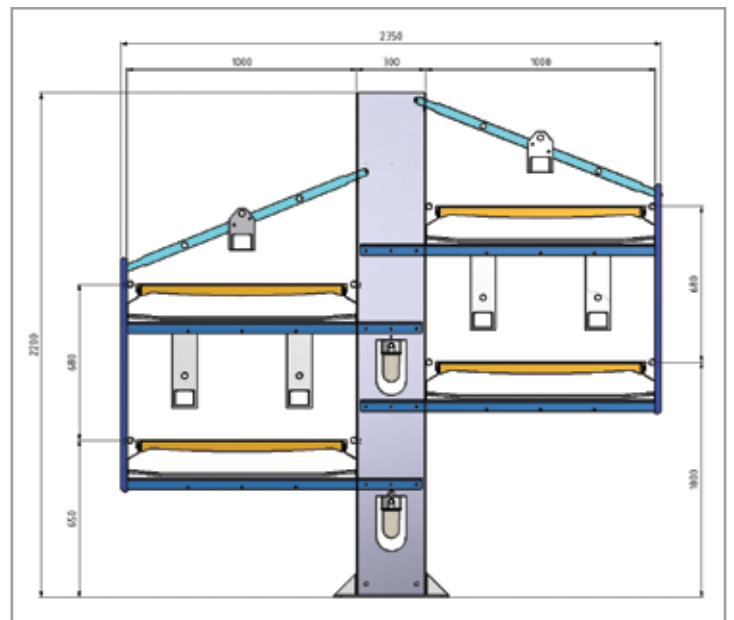
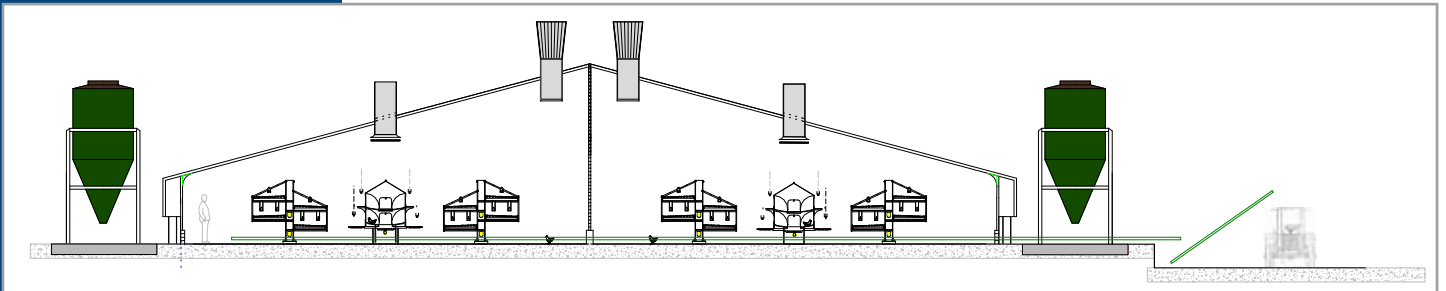
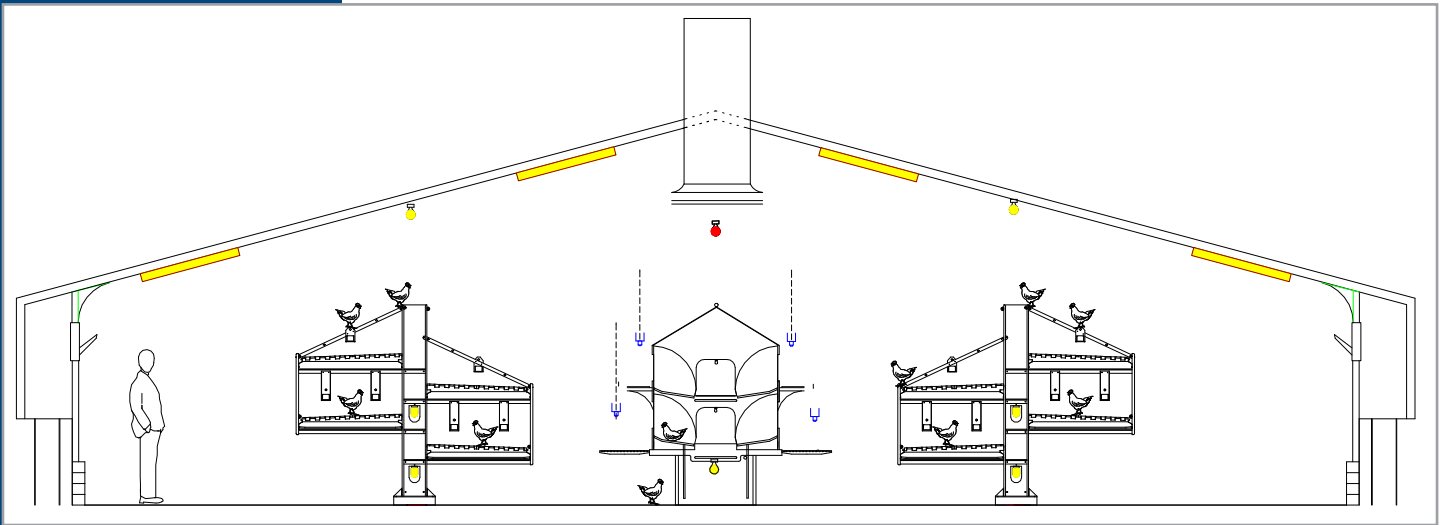

Combination design with, or without, extra manure belt.

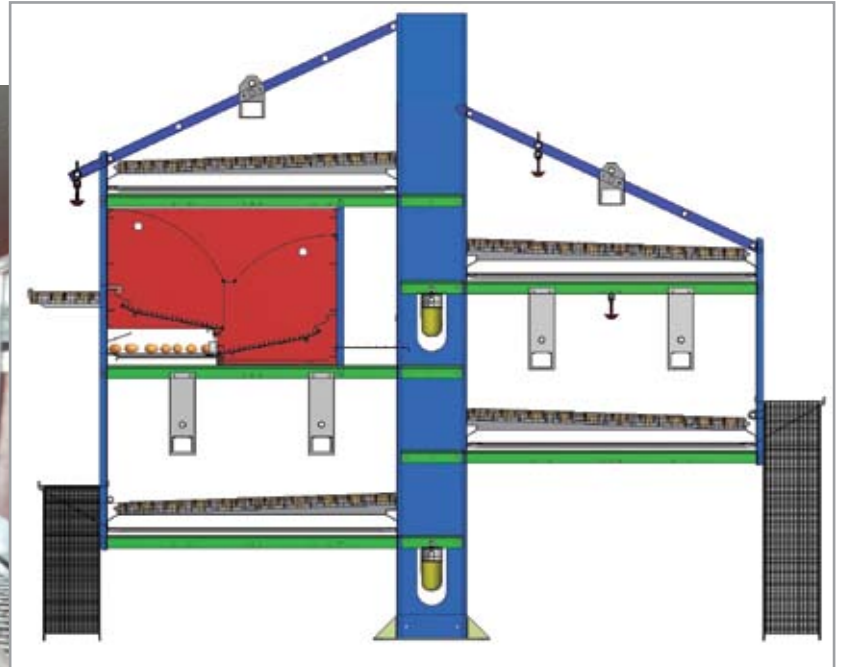

Designed and produced by Dialhouse Visual Communication www.dialhouse.co.uk

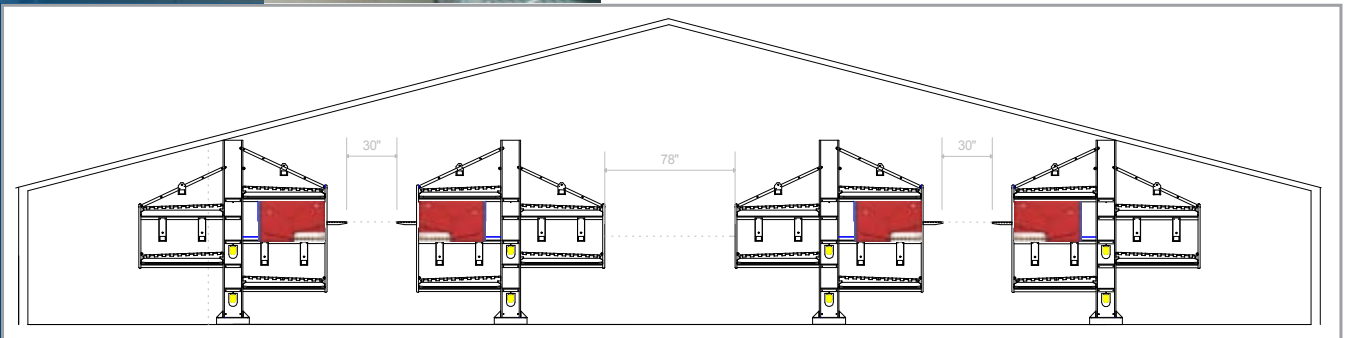

Dealer:

Integrated Nest System

- Double sided nest, giving access from both sides
- Minimises distance birds have to travel to the nest
- Single large egg belt
- All birds visible from the floor
- Very easy management

Wiley Fields Farm, Wiley, Rugby, Warwickshire CV23 0SQ United Kingdom
 Tel: +44 (0) 1455 553234 Fax: +44 (0) 1455 550593
 info@potterspoultry.co.uk www.avinest.com (non-UK customers)
 www.potterspoultry.co.uk (UK customers)