



Installation Instructions for GrowerSelect HS638 Igniter Replacement

Warning - Disconnect all electrical power sources to heater before installing igniter!

Caution! – Verify heater is cool prior to touching internal surfaces!

Tools Required 11/32” Nut Driver

Parts List

Part #	Quantity	Description
HS635	1	Igniter Mini 2" 120 VAC Stainless Steel
HS0408-4390	1	Bracket Igniter 2" New Style
616551	3	Machine Screw #8-32 X 1/2" Phillips Pan Head Zinc
606801	3	Keps Nuts #8-32 Zinc

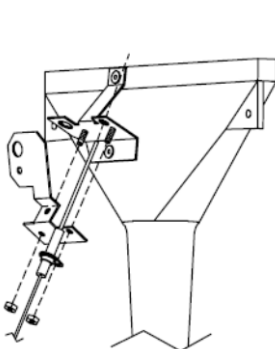

Figure 1

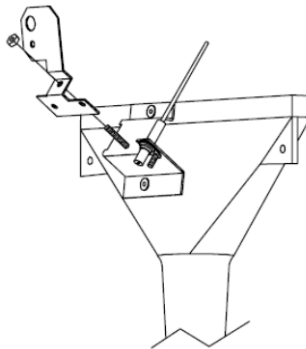

Figure 2

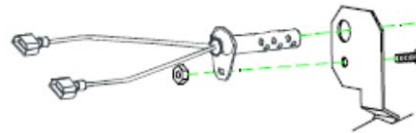

Figure 3

Instructions

1. Disconnect power to the heater.
2. Disconnect the two lead wires from the existing igniter. Remove the # 8-32 kep lock nut. Remove the igniter from the existing bracket. Refer to one of the figures above for installation of the new replacement bracket.
3. Reference Figure 1, if heater is 120,000 BTU or larger. Before installing replacement bracket, remove # 8-32 kep lock nut and the flame probe from the existing bracket. Attach the replacement bracket and replace the flame probe to the existing bracket. Secure them in place using the # 8-32 kep lock nuts.
4. For 75,000 BTU or smaller heaters, reference Figure 2. Attach the replacement bracket and secure it in place with # 8-32 kep lock nut.
5. After attaching the replacement bracket to the existing bracket, insert the new igniter as shown in Figure 3. Use # 8-32 X 1/2" machine screw and nut to secure the igniter to bracket.
6. Confirm the tip of the igniter extends over the top of the cast iron burner. Also be sure that the igniter does not contact cast iron burner or internal heater components.
7. Reconnect the lead wires to the new igniter.
8. Connect power to heater and check for proper operation.
9. Installation complete.

Part Number HS638 Rev A1

Market: Hog