



HST1500 G-LOGIC END OF LINE CONTROL PAN - TURKEY

General Installation Notes:

Make sure that power is disconnected from system prior to servicing.

Installation of this equipment and related OEM equipment should be in accordance with these instructions, OEM's installation instructions and local codes (if applicable). Failure to follow specified instructions may cause damage to equipment and/or personal injury or death.

Take special note of any Warnings or Safety Decals on the equipment and in manuals.

Always wear protective clothing and any applicable Personal Protective Equipment (Safety Glasses and/or Ear Plugs) when working with the equipment.

Discarded materials, equipment and boxes should be recycled in accordance with local and national codes.

Note: Control Pan is to be wired in accordance with all local, state and national wiring codes. All wiring sizes and fuse capacities are to be sized according to national electrical code specifications or other applicable regulations.

Safety Instructions:

Read all safety messages in this manual and on equipment safety decals. Follow recommended precautions and safe operating practices.

Ground all electrical equipment for safety.

Ground all non-current carrying metal parts to guard against electrical shock.

Always keep safety decals in good condition and replace missing or damaged decals.

Do not connect rigid conduit to control pan enclosure.

HST1500 Installation Diagram:

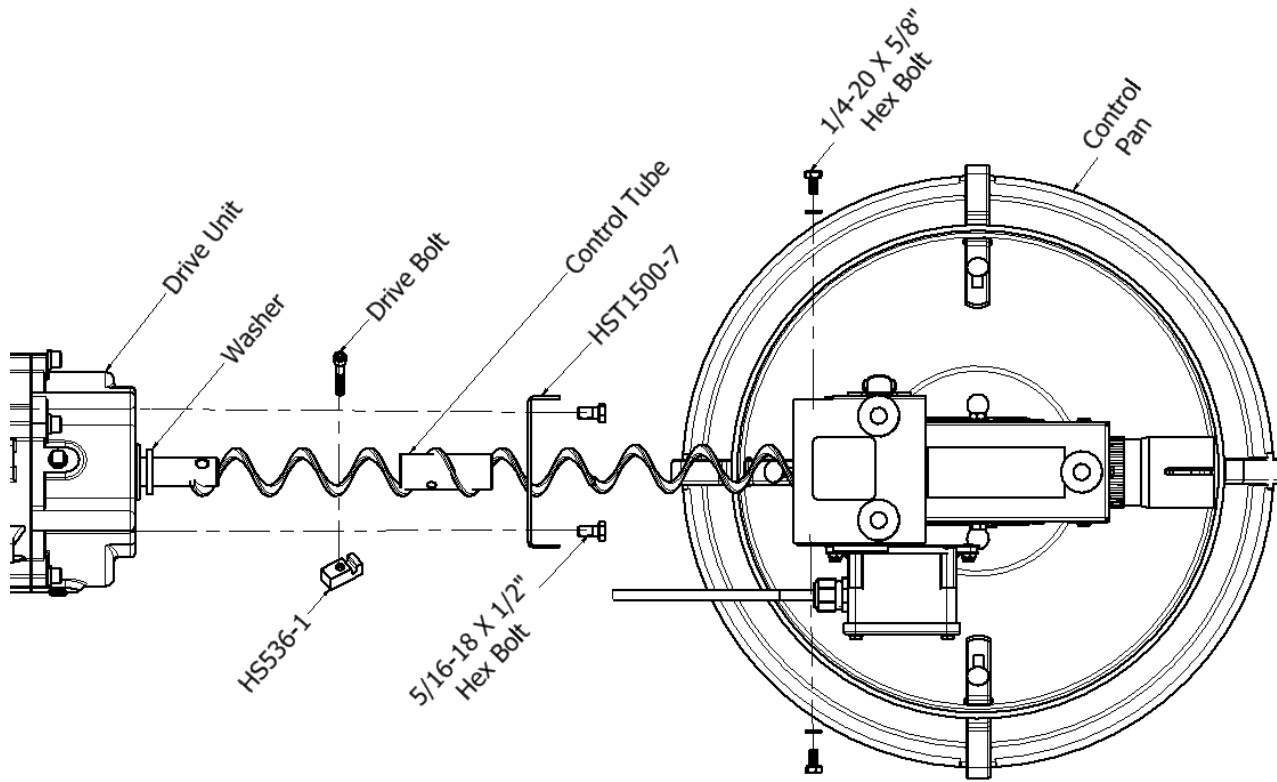

Wiring:

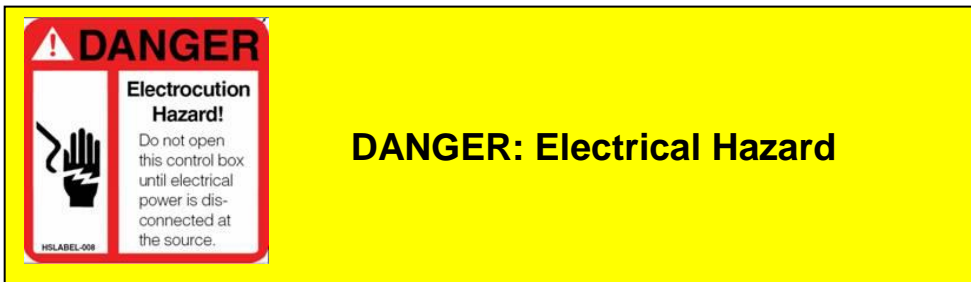

IMPORTANT Disconnect all electrical power before attempting installation of this (or any equipment), inspecting or servicing.
 Ground all electrical equipment in accordance with applicable codes. Do not assume equipment will automatically be grounded due to incidental metal-to-metal contact.
ALL electrical wiring must be done by a qualified electrician in accordance with local and national electric codes.

Motor Wiring: See motor nameplate for wiring instructions.

HST1500 G-Logic End of Line Control Pan - Turkey

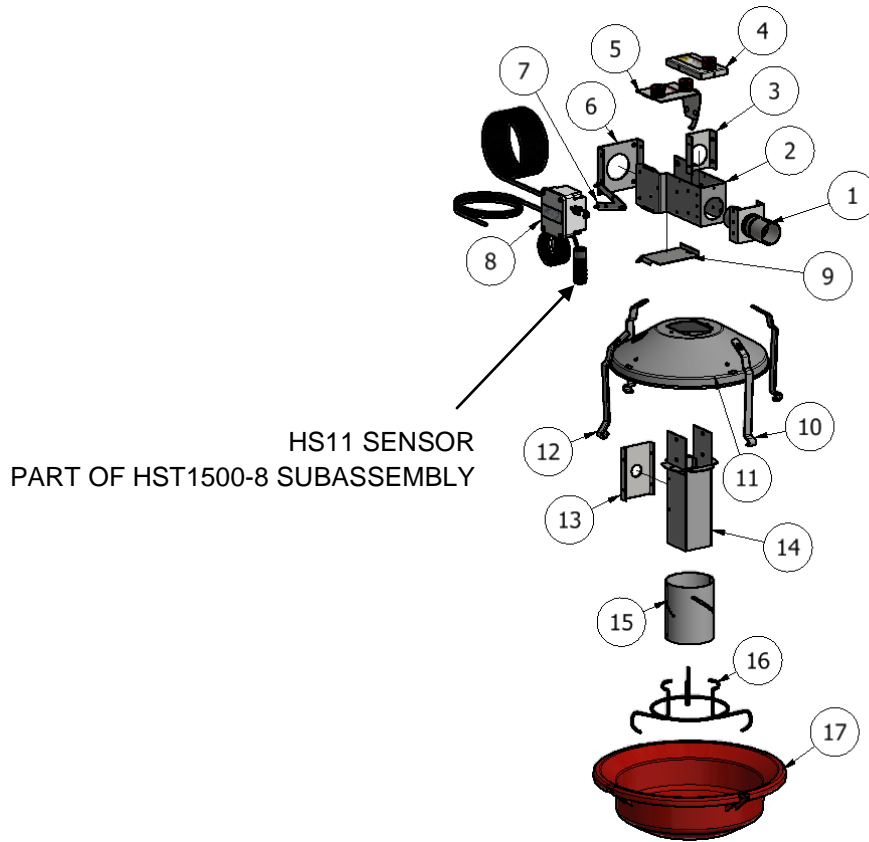

PARTS LIST			
ITEM	QTY	PART NUMBER	DESCRIPTION
1	1	HST1500-24	INLET, COMPLETE, EOL CONTROL, 2 IN
2	1	HST1500-12	EOL CONTROL UNIT, BODY
3	1	HST1500-38	U-BRACKET, CONTROL UNIT - TURKEY
4	1	HST1500-34	COVER, HOPPER, EOL UNIT, COMPLETE
5	1	HST1500-44	COVER ASY, HOPPER - EOL CONTROL - TURKEY
6	1	HST1500-7	EOL CONTROL UNIT, BRKT, DRIVE END - TURKEY
7	1	HST1500-5	BRACKET, CONTROL BOX, EOL CONTROL UNIT, TURKEY - COMPLETE
8	1	HST1500-8	CONTROL BOX ASSY, G-LOGIC, TURKEY
9	1	HST1500-18	REAR SHIELD, HOPPER - EOL CONTROL - TURKEY
10	3	HST1000-8	LEG, SUPPORT, FEEDER, SHIELD
11	1	HST1500-1	EOL SHIELD, TURKEY FEEDER
12	1	HST1000-14	LEG, SUPPORT, SWINGING
13	1	HST1500-9	SUPPORT, SENSOR, EOL UNIT, TURKEY
14	1	HST1500-46	TUBE, ASSY, DROP
15	1	HS07091707	RING, ADJUSTMENT, FLUE
16	1	HST1000-10	SUPPORT, ADJUSTMENT FLUE
17	1	HST1000-1	PAN, TURKEY FEEDER

This equipment must be installed in accordance with all State and Local Codes and applicable Regulations which should be followed in all cases. Authorities having jurisdiction should be consulted before installations are made.



**Hog Slat, Inc.
PO Box 300
Newton Grove, NC 28366**

**Phone: (910) 594-0219
Fax: (910) 594-1392**

www.hogslat.com

Copyright © 2017 by Hog Slat, Inc.

Part Number: HSMANUAL-121 Rev A1
Market: Poultry