



HOG SLAT

Pit Scraper System

Installation Instructions

General Installation Notes:

Make sure that all power is disconnected at source prior to installation.

Installation of this equipment and related OEM equipment should be in accordance with these instructions, OEM's installation instructions and local codes (if applicable). Failure to follow specified instructions may cause damage to equipment and/or personal injury or death.

Take special note of any warnings or safety decals on the equipment and in this manual.

Always wear protective clothing and any applicable personal protective equipment (safety glass and/or ear plugs) when working with the equipment.

Discarded materials, equipment and boxes should be recycled in accordance with local and national codes.

Note: Power Unit is to be wired in accordance with all local, state and national wiring codes. All sizes and fuse capacities are to be sized according to national electrical code specifications or other applicable regulations.

PT# HSPSMANUAL

Basic Layout and Dimension Requirements:

Figure 1 - Pit Layout

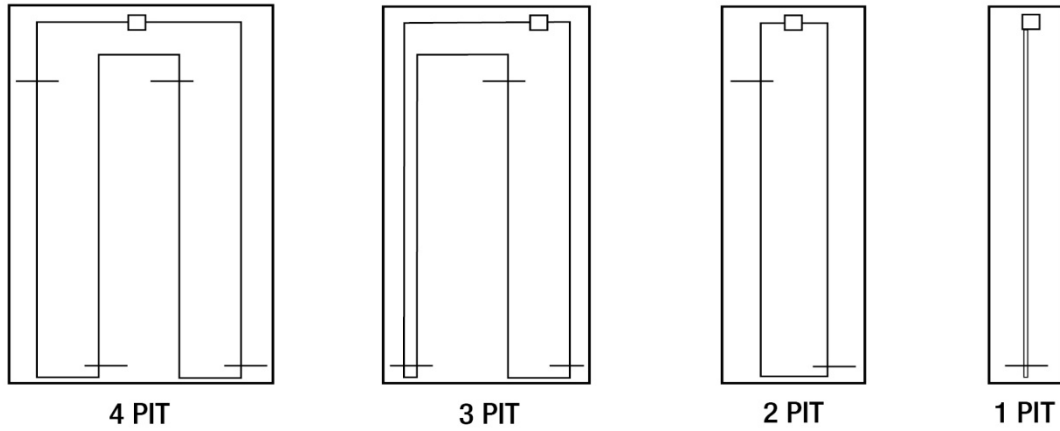
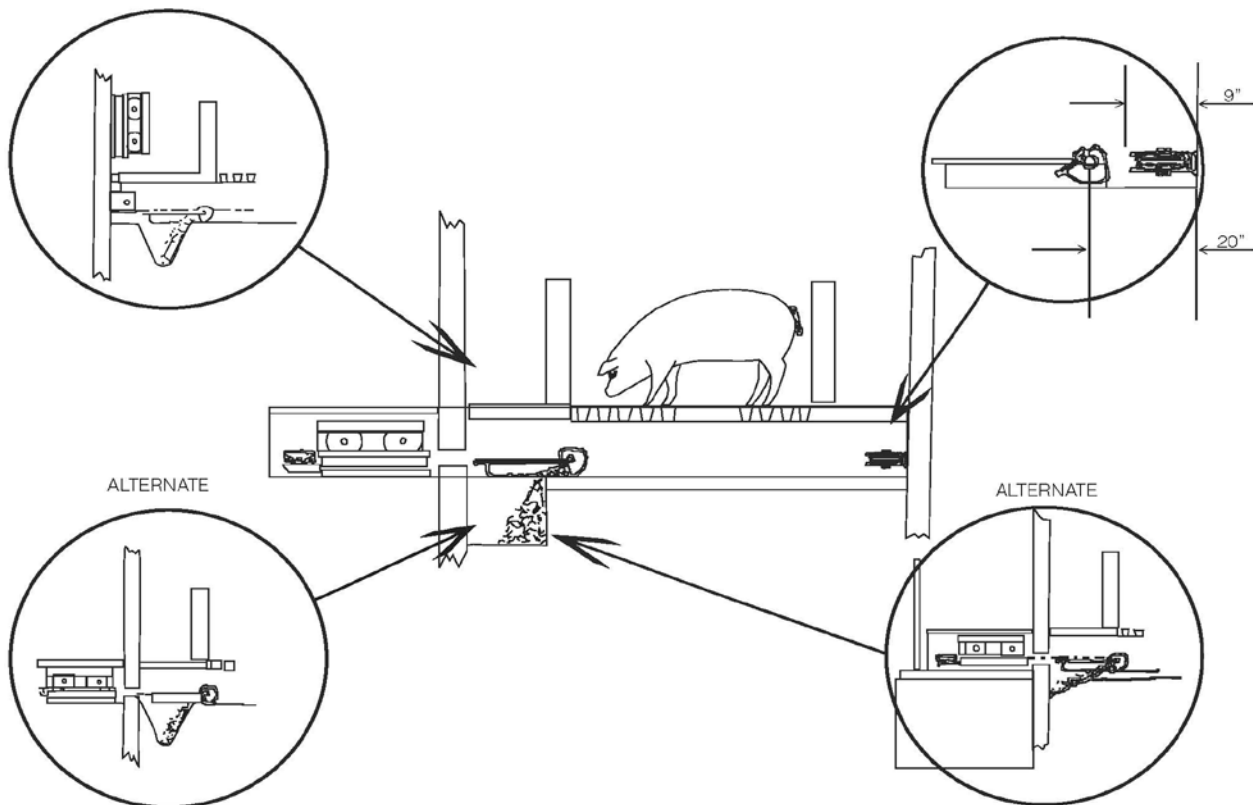
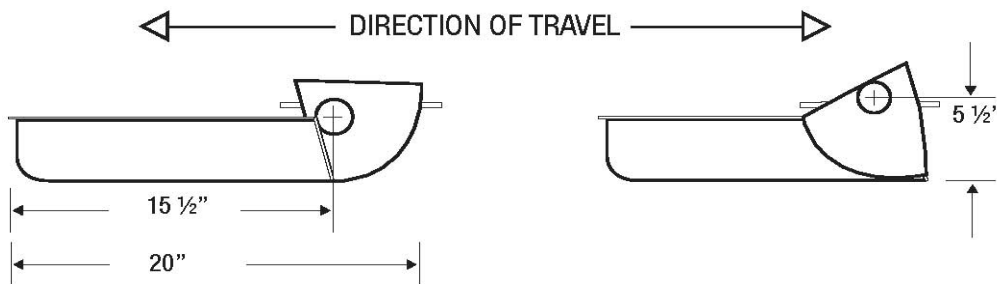

Figure 2



Scraper Clearances

Approximately 3" clearance is required between the end of the scraper and the pit wall.



System Recommendations

The drive unit and corner wheel assemblies of the pit scraper system must be protected from freezing. Corner wheels, steel cable and metal parts may seize due to freezing.

Avoid and remove any obstruction to the cable system, corner wheel assemblies and scrapers.

It is not recommended to use the scraper system in an open pit with animals present.

Hog Slat is not liable for injury to animals.

Construction of the Pit

To ensure satisfactory operation of the scraper system, the depth of the pit must be 8" minimum below the slat floor. Recommended depth of the pit is 12".

Interior walls of the pit must be free of any voids or protrusions which could cause the scraper to bind during operation.

Pit bottom must be concrete.

For retrofitting into existing pits, all cracks, voids and seams must be repaired with suitable concrete patch repair materials.

Marking Gutters

Find and mark center line of each gutter with a chalk line. On two-gutter systems, mark the crossovers also as the lines will intersect each other showing the location where the corner wheel assemblies are to be installed.

Install Power Unit and Corner Wheels

According to your system layout design plan (see Figure 1), place the power unit and corner wheel assemblies in their approximate locations. Before fastening these units in place, be sure to align them properly so that the cable will be in the center of the pit. The corner wheels should be installed on the opposite end of the building from the power unit. On single-gutter units the corner wheel can be mounted horizontally or vertically.

Install the non-adjustable corner wheels on the same end as the power unit. Locate the corner wheels as shown on the drawing. See Figure 1.

The power unit can be installed in several positions according to your gutter width and building design. Position the cable drive cable pulley in line with the cable and secure the power unit to the floor or wall with adjustable brackets. Normally, one wrap of the cable is sufficient to pull the blades. Always use stainless steel cable.

The power unit and corner wheel assemblies should be secured to the floor and /or walls with lag bolts and cement anchors.

Increasing or decreasing cable tension can be achieved by adjusting the power unit adjustment bolt.

Install Scrapers

Install the scraper(s) in the gutter. On single-gutter installations, position the scraper in the end opposite the power unit and as close to the corner wheel as possible. If two scrapers are used, position one in each gutter and at opposite ends of the gutter. One should be at the corner wheel and the other at the dump point near the power unit.

The blades are designed to remove an adequate amount of manure without overloading the system. (Part failures due to overloading the system are not considered “defective” under warranty)

The scraper blade is designed to move manure to a dump point. If the scraper does not move freely through the pit area and more clearance is needed, cut an equal amount off each end of the scraper. Leave it long enough to clean the pit floor.

Install the Stainless Steel Cable

Use only 5/16” -7x19 stainless steel cable in the system. Hog Slat part # 617276

Feed the cable through the power unit and corner wheels. Attach the cable to the cable bracket on the scraper blade leaving 3-4" from the point where you want the blade to stop. Pull excess cable between the blade and the power unit through the power unit.

Thread the cable through the scraper system as shown in Figure 1.

No cable clamps or connectors can pass through the corner wheels or power unit drive pulley.

Cable Adjustment

Remove the cable clamps and the cable from the scraper. Pull the cable snug and lap the cable ends one on top of the other on the cable bracket and install two cable clamps (do not tighten the clamps).

Use a come-a-long or suitable cable-tightening device to tighten cables (do not over tighten the cable—approximately 200# tension is all that is necessary on the cable). Tighten the cable clamps.

Turn the power unit by hand to pull the blade up to the discharge point. Go over to opposite pit and to the opposite end of the building and position the second scraper at the point at which the blade will stop in reverse. Cut a piece of cable approximately 12" long to lay over top of continuous cable going across the scraper. Attach to cable scraper with clamps and tighten.

To figure required cable lengths, add the combined lengths of all pits, plus the return side of a single or odd pit if used, plus the total length of all crossovers, plus a minimum of 5 ft. to lace the power unit. It is best to overestimate the lengths as spliced cable cannot be used to go through the power unit or corner wheels.

After the cable is connected to the scrapers and run through the power unit, test the unit to see if it will pull the scrapers.

Since cable cannot be spliced and run through the power unit, replacement is costly. It pays to treat them carefully. Here are some precautions:

- A. Don't overly stress cable by trying to pull large loads. The cable has enough strength to pull most any load the unit will develop, but overly stressing will cause other parts to deteriorate or fail. (As mentioned before, this situation is not covered under warranty.)
- B. On installations where cables go through a passage under the floor or behind a wall, be sure cable does not drag over sharp edges. Use PVC pipe or any other smooth object to go through passages or walls for cable routing.

Testing

Turn on the unit to see if it will pull the scraper under a no-load condition. If it will not, you must determine how much slack you have and perhaps shorten the cable at the scraper blade connection. If you do not need more tension to get the scraper to operate, adjust the adjustment on the power unit bracket or corner wheels at this time. Tighten only enough to make the scraper move in both directions.

After the unit has run a few days, it may be necessary to adjust cable tension again, but only take up enough slack to keep the pulley from slipping. Too much tension can damage the cable and equipment.

If you have the adjustment fully taken up, you will need to loosen up and re-tighten the cable at the scraper. Then tighten the tension again. Only tighten it enough to get it to pull the load of manure with the frequency you have chosen for your cleaning schedule. The cable should be tight enough to pull a normal load.

Maintenance

Periodically (8 weeks or between pig transition):

- Check all bolts on the power unit, including the floor mounting bolts.

- Check all cable clamps.

- Check cable tension.

- Clean and inspect scraper blades for excessive wear and damage.

Trouble shooting

Power unit will not run:

- Check fuse or circuit breaker. Have electrician check components in the control panel to make sure all components operate.

- Check for loose wires.

- Check for loose belt.

Cable slipping:

- Adjust the cable tension.

Wiring Instructions

Note: Scraper is to be wired in accordance with all local, state and national wiring codes. All wiring sizes and fuse capacities are to be sized according to national electrical code specifications or other applicable regulations.

The recommended switch for the Hog Slat Scraper Systems is a “Maintained” Forward-Off-Reverse 20 amp either 1-Phase or 3-Phase switch depending on electrical supply. “Maintained” means motor or Scraper System stays turned on until operator physically turns system off.

Caution

Scraper System should never be left unattended during operation. Serious physical injury or system damage could result from a Scraper System being unattended.

Check and make sure the motor voltage corresponds to the supply voltage.

1-Phase 4-Wire Motor Connection

The connection diagram below is for a typical connection of a 1-phase 4 wire motor. It is applicable for either 115 or 230 volts. To ensure proper connection, please refer to the motor nameplate for specific connection details and voltage settings.

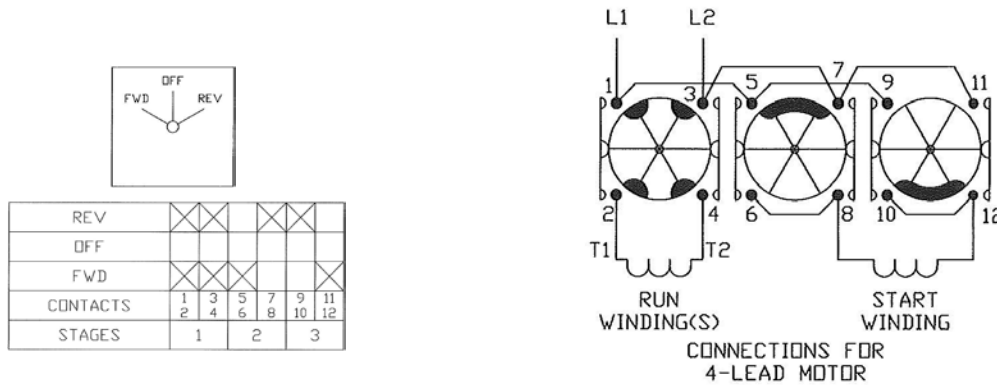

Note: If Forward and Reverse are backwards, reverse the START WINDING leads connected to terminals 8 and 12.

3-Phase 3-Wire Motor Connection

The connection diagram below is for a typical connection of a 3-phase 3 wire Motor. To ensure proper connection, please refer to the motor nameplate for specific connection details and voltage settings.

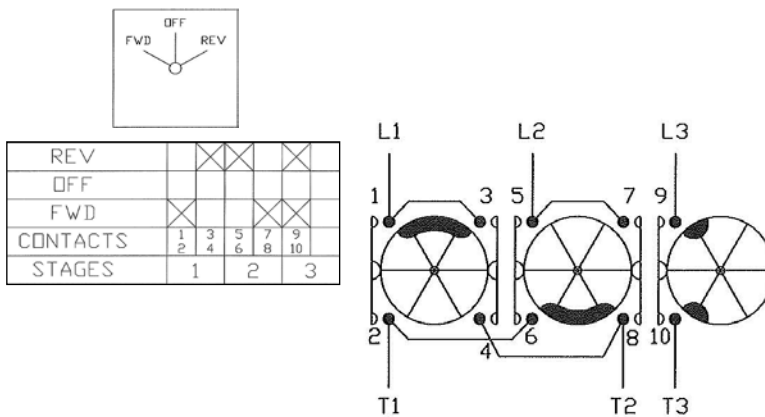

WARNING

ELECTRICAL SHOCK HAZARD!

- Scraper installation and wiring should only be done by qualified and properly trained individuals.
- Failure to follow the above warning can cause improper equipment function, premature failure of equipment or electrical shock, leading to property damage or personal injury.

Scraper Blade Assembly

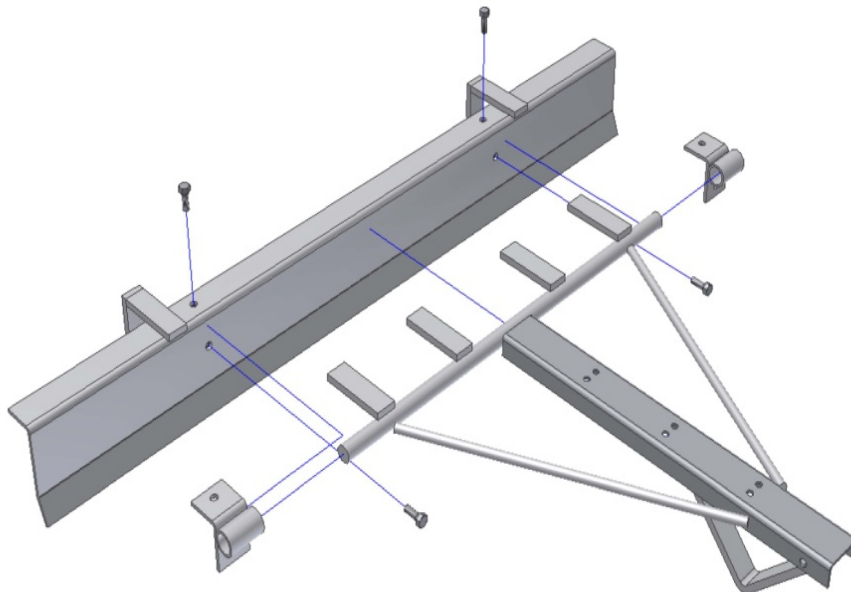

Replacement Parts

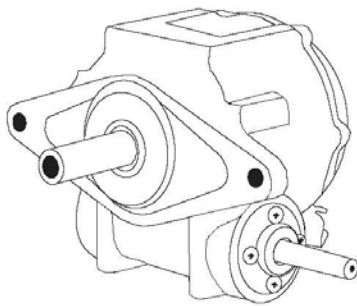

Scraper Gear Reducer

Item#	Description
452-717	Scraper Gear Reducer

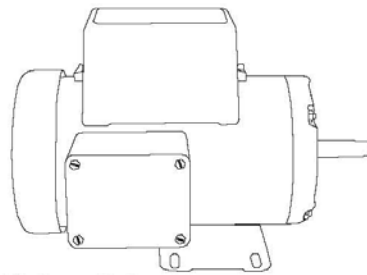

Motor - Belt

Item#	Description
5330014	3/4 hp Motor
HSA26	"V" Belt

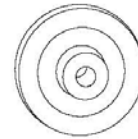

Scraper Pulley

Item#	Description
PAK2558	2 1/2" x 5/8" pulley (motor)
PAK4458	4 1/2" x 5/8" pulley (gear reducer)

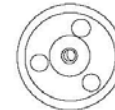

Sheave Hub

Item#	Description
452-718	For scraper gear box

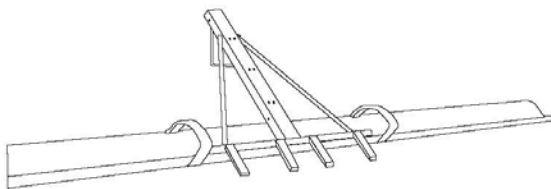

Stainless Steel Scraper

Item#	Description
8070280500	Stainless steel - 6' 5"
8070240500	Stainless steel - 7' 1"
8070270500	Stainless steel - 9' 2"

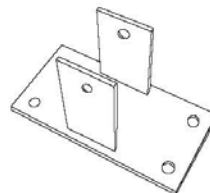

Scraper Bracket

Item#	Description
8070250500	Stainless Steel

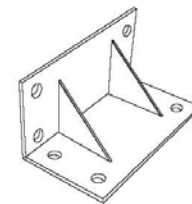

Floor Bracket Scraper

Item#	Description
8070260500	8' x 5" Stainless Steel

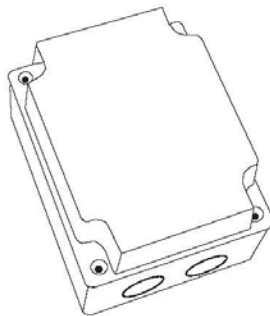

Manual Scraper Switch

Item#	Description
452-457	Manual Scraper Switch

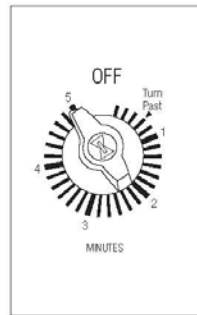

5 Minute Timer

Item#	Description
590311	5 minute timer



Scraper Stop Rod

Item#	Description
2012580500	1/2" x 58"

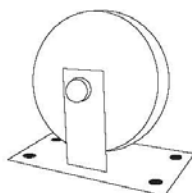

Corner Wheel Assembly

Item#	Description
452-708B	Cast Steel

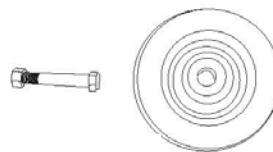

Axle, Wheel

Item#	Description
605045	Axle Bolt 1/2 X 3" SS
60693	Nylon Lock Nut 1/2" SS
59518	Wheel 6" Cast Steel



Cable

Item#	Description
61726	5/16" - 7 X 19 SS

WARRANTY AND ACCEPTANCE OF ORDER TERMS

- (1) Purchaser agrees to pay in full for the subject goods of this order within the terms stated on the invoice. In the event that purchaser fails to so pay, purchaser shall be liable to: Hog Slat, Incorporated; Hog Slat, Incorporated DBA Georgia Poultry Equipment Company; Hog Slat, Incorporated DBA Heartland Products Company; or Hog Slat, Incorporated DBA Parking Bumper Company (hereinafter referred to as "Hog Slat") for all costs incident to recovery of the delinquent amounts including legal fees and for payment of interest at the rate of 1 ½% per month.
- (2) Hog Slat hereby expressly warrants any product manufactured by it for one year against any damage to the product caused by defects in material or workmanship excluding paint finish. The exclusive remedy for breach of this warranty shall be the repair or replacement of the product, the choice of which shall be within the exclusive discretion of Hog Slat, at no charge to purchaser. Written approval must be obtained from Hog Slat prior to any return of goods. Hog Slat shall in no event be liable to purchaser for any consequential damages arising from the failure of the product to satisfy this warranty.
- (3) The warranty provided for in paragraph 2 above shall run from the date the product(s) is received by the purchaser.
- (4) ANY IMPLIED WARRANTY OF MERCHANTABILITY, ANY IMPLIED WARRANTY OF FITNESS FOR A PARTICULAR PURPOSE, ANY IMPLIED WARRANTY AGAINST INFRINGEMENT, AND ANY OTHER IMPLIED WARRANTY, ON ANY PRODUCT SUPPLIED BY HOG SLAT, WHETHER OR NOT THE PARTICULAR COMPONENT IS MANUFACTURED THEREBY, ARE HEREBY EXCLUDED AND DISCLAIMED.
- (5) The agreement between Hog Slat and purchaser shall be governed by the laws of the State of North Carolina. If any provision or portion thereof contained herein is found to be unenforceable under the law, the remaining provisions and portions shall not be denied their full force and effect.



THIS PAGE INTENTIONALLY LEFT BLANK





This equipment must be installed in accordance with all State and Local Codes and applicable Regulations which should be followed in all cases. Authorities having jurisdiction should be consulted before installations are made.



**Hog Slat, Inc.
PO Box 300
Newton Grove, NC 28366
Phone: (910) 594-0219
Fax: (910) 594-1392
www.hogslat.com**

Copyright © 2013 by Hog Slat, Inc.

**Part Number: HSPSManual
HSART-205 Revision A2**

